

Pressure Sensor AP50KL

- Suitable to measure dynamic air gauge pressure;
- Small size, M5×0.5 Mounting;
- Measurement range 50kPa, over load 150%;
- Response time<0.1ms;
- Anti-shock>100g.



Pressure sensor AP50KL, based on piezo resistance effect, zero at ambient, includes a full bridge circuit. There is resistance changed by measuring different air pressure, then the voltage signal can be converted according to the resistance difference. The reasonable MEMS process makes the sensor good linearity performance and stability. The sensor includes wear-resisting cable with default length 8m. The LEMO connector and Dallas ID are optional.

Technical Specification (5V, 25°C):

Name	Unit	Value
Meas. Range	kPa	± 50
Over Load	kPa	± 75
Non-linearity	%FS	<0.5
Response Freq.	kHz	DC-10
Offset	mV	<5
Warm Up	ms	<50
Excitation Voltage	VDC	5
Power Current	mA	<10
Anti-Shock	g	>100
Isolation	MΩ	>100
Operation Temp.	°C	-20~70
Storage Temp.	°C	-40~125
Case Material	/	Stainless Steel
Weight	grams	2.5
Dimension	mm	20.8× 11.0

Default Cable Length 8m;

Connector and ID as required.

Drawing Reference:

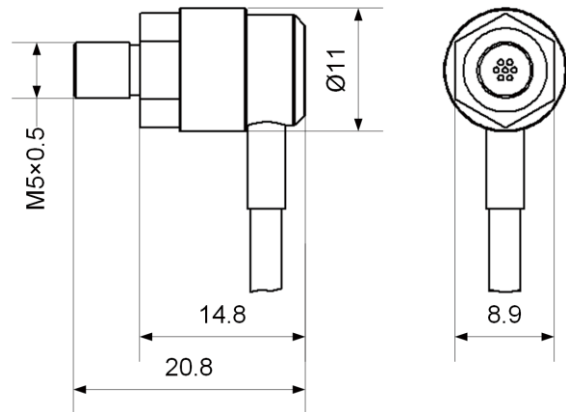

Wire Assignment:

Red	Excitation+
Black	Excitation-
White	Signal-
Green	Signal+
Shield	Connector Case

Other mounting screws are optional.