

Displacement Sensor WY-45

- Push rod style displacement sensor;
- Small size, and easy install;
- Applied to various displacement measurement, vehicle crash test;
- Measurement range 45mm;
- Lower push force and fast response;
- Anti-Shock>100g.



The push rod displacement sensor WY-45 mainly contains a sliding potentiometer. When the sliding piece moves, the resistance of the potentiometer changes accordingly, and the displacement has a good linear relationship with the rate of change of resistance. Through Ohm's law, the displacement measurement can be realized after converting into an electrical signal.

Specification (5V, 25°C)

Name	Unit	Value
Range	mm	45
Push force	N	<0.3
Non-Linearity	%FS	<0.1
Response	kHz	>10
Warmup	ms	<50
Excitation	VDC	2~15
Input Resistance	kΩ	10
Anti-Shock	g	>100 (3ms)
Insulation Res.	MΩ	>100
Opera. Temp.	°C	-10~60
Store Temp.	°C	-40~100
Material	/	Metal body

Wire length default 8m;

Connector and ID as required.

LEMO Connector is optional;

Sensor type: Full bridge (signal- and excitation- is short as default), and shunt is not selected.

Sensitivity: **22.2 (mV/V)/mm or 11.1 (mV/V)/mm.**

Dimension:

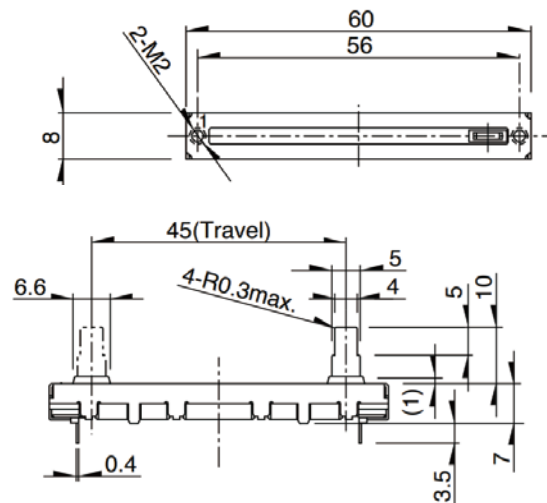

Wires define:

Red	Excitation+
Black	Excitation-
Green	Signal+
White	Signal-
Shield	Connector Case